

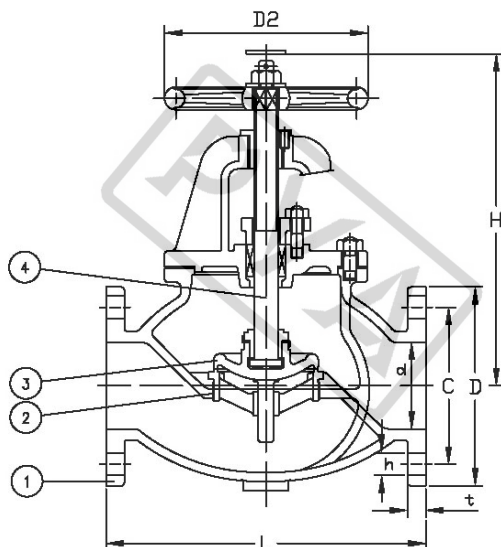

# JISF7307 10K CAST IRON GLOBE VALVE



Pressure Test		MPa	
Nominal Pressure/PN	1.0MPa	Shell Test	2.1 MPa
		Seat Test	1.54 MPa

Main material for fittings			
Item	Fittings	Material	Mark
1	Body	Cast Iron	FC200
2	Bonnet	Cast Iron	FC200
3	Disc	Stainless Steel/Cast Bronze	SS420/BC6
4	Seat	Stainless Steel/Cast Bronze	SS420/BC6
5	Stem	Stainless Steel/Forged Brass	SS400/C3771BD
6	Handwheel	Cast Iron	FC200

Main data for flange connection						
Model	Face To Face	Flange Diameter	Flange PCD	Flange Hole	Height	Weight
	L	D	C	n* $\varnothing$ d	H	kgs
F7307 10K50	220	155	120	4 $\times$ $\varnothing$ 19	285	19.9
F7307 10K65	270	175	140	4 $\times$ $\varnothing$ 19	310	28.7
F7307 10K80	300	185	150	8 $\times$ $\varnothing$ 19	320	32.4
F7307 10K100	350	210	175	8 $\times$ $\varnothing$ 19	370	48.7
F7307 10K125	420	250	210	8 $\times$ $\varnothing$ 23	420	73.1
F7307 10K150	490	280	240	8 $\times$ $\varnothing$ 23	470	104
F7307 10K200	570	330	290	12 $\times$ $\varnothing$ 23	555	162
F7307 10K250	740	400	355	12 $\times$ $\varnothing$ 25	680	304
F7307 10K300	840	445	400	16 $\times$ $\varnothing$ 25	770	458

Design	Check	Signature	Logo	Supplier
asbsey	Chrit	Figor		PROMET VALVES AUSTRALIA
JAN.01,2013	JAN.01,2013	JAN.01,2013		

## PROMET VALVES AUSTRALIA

1A Green Road Woodville West SA 5011 Australia / Tel:+61 8 8268 1777 / Fax:+61 8 8268 1711  
 promet@prometvalves.com / www.prometvalves.com / ABN47 096 425 697